

"The use technology of a special synthetic magnetic field"

"Introduction"

About drastic improvement technology of fateful exhaust-gas treatment technology of an automobile,

About 130 years have passed since gasoline engine cars were invented by "Daimler" until today.

As far as the driving principle of automobiles is based on the explosive thermal expansion pressure due to the combustion of fuel oil, reduction of exhaust gas by the combustion becomes inevitably a fatal technical problem.

However, despite 130 years since the invention of the automobile by Daimler, a drastic technology that can simultaneously greatly reduce carbon dioxide (CO₂) due to complete combustion and harmful exhaust gas due to incomplete combustion, has not been developed to this day.

For that reason, it has already been announced that the manufacture of conventional gasoline engine and diesel engine cars will be banned in the near future by the UK and French governments in order to protect the global environment from conventional automobile exhaust gas.

In addition, in the combustion technology of the conventional automobile manufacturer all over the world a negligibly small vaporizing expansion pressure in the combustion of the fuel oil in the sealed combustion space is merely generated.

On the other hand, according to the fuel oil by my "The use technology of a special synthetic magnetic field", it was confirmed that a new unknown explosive vaporous expansion pressure that reaches 10% to 20% of the explosive thermal expansion pressure by conventional combustion, occurs immediately before the explosive thermal expansion pressure by conventional combustion.

Therefore, "Formation of the air-fuel mixture gas that can burn out completely" and "Shortening in burning time" each can be improved dramatically with the generation of a new unknown explosive vaporous expansion pressure caused by "The use technology of a special synthetic magnetic field".

Needless to say, due to progress of research on "The use technology of a special synthetic magnetic field", it is sufficiently possible to increase the generation amount of the new unknown explosive vaporous expansion pressure to the current 10% to 20% or more.

As mentioned above, my "The use technology of a special synthetic magnetic field" is a revolutionary technology that can solve the above-mentioned fatal technical problem.

I'm convinced that "The use technology of a special synthetic magnetic fields" is a technology that can build bridges that can connect to the present and the future regarding energy securing, reduction of carbon dioxide (CO₂) and prevention of air pollution.

In the following, the materials that are thought to have generated a new and unknown explosive vaporous expansion pressure by the fuel oil managed by "The use technology of a special synthetic magnetic field" are presented.

1. The outline of “Special synthetic magnetic field”

- (a) “The use technology of a special synthetic magnetic field” in an alternating magnetic field mentioned below is the technology of “Special synthetic magnetic field” that the value of addition of both magnetic forces that exist on symmetrical positions by centering a conversion point of magnetic poles becomes zero.
- (b) Below is explained about “The use technology of a special synthetic magnetic field” that is particularly used in fuel oil, water and air.
- (c) Below is the result of the study that was guided from the many test results that were already carried out in “[Test data in Chapter 1](#)”, “[Test data in Chapter 2](#)” and “[Test data in Chapter 3](#)”.
- (d) A “The use technology of a synthetic magnetic field” brings about a characteristic change completely different from the conventional characteristic of a substance.

2.

Explanation diagram of “Special synthetic magnetic field”

Fig. 1

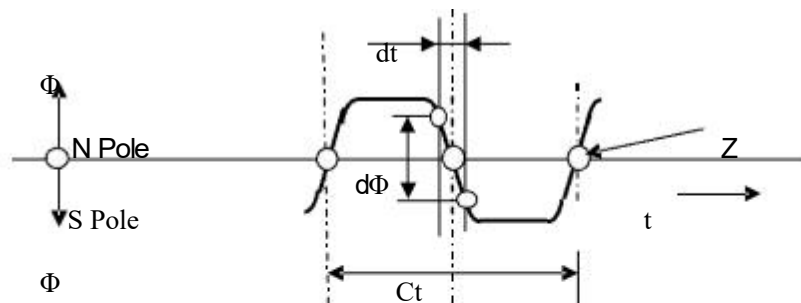
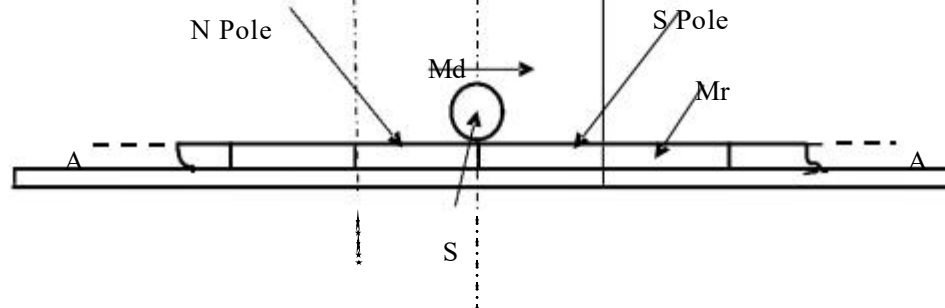

Fig. 2



Mr : Magnet row

Φ : Magnetic flux density

t : time

Ct : One cycle

Z : Conversion point of magnetic pole

S : Substance

A-A Section : Main surface of magnetic flux density

Md : Direction of movement of a substance : The direction that is perpendicular to the surface that the different poles of the permanent magnets adsorb each other.

3. Explanation of a “Special synthetic magnetic field”

- (a) Move the substance (S) with a specific speed in a specific direction (Md) along the magnet row (Mr).
- (b) At this time, in conversion point of magnetic pole (Z), the highest change rate ($d\Phi/dt$) in a original and the reverse direction is induced to an atom of a substance (S) in turn according to a specific moving speed.
- (c) In other words, the electronic energies (E) due to the maximum magnetism in the original and reverse directions are alternately induced to an atom of the substance (S), and the substance (S) is made high energy.
- (d) At this time, the way of the motion of the electronic energy induced to an atom of a substance (S) is the same as the way of the motion of the electronic energy represented by the magnetic quantum number in the definition of quantum theory.
- (e) Therefore, according to the substance (S) managed by "The use technology of a special synthetic magnetic field", the characteristic change completely different from the conventional characteristic of the substance (S) expressed with the principal quantum number in the definition of the quantum theory, is generated.
- (f) According to fuel oil, water and air managed by "The use technology of a special synthetic magnetic field", characteristic changes that are totally different from conventional characteristics of fuel oil, water and air are generated.

For above reasons, is theoretical grounds of the effects to occur by "The use technology of a special synthetic magnetic field".

Table of contents

Section 1 : About technical background

Section 2 : About “The use technology of a special synthetic magnetic field”

- Section 3 : About the explanation with the quantum theory by “The use technology of a special synthetic magnetic field”
- Section 4 : A reduction rate of the fuel consumption of heat engine by fuel oil managed by "The use technology of a special synthetic magnetic field"
- Section 5 : Temperature drop caused by the combustion of fuel oil managed by "The use technology of a special synthetic magnetic field"
- Section 6 : Noise and vibration caused by the combustion of fuel oil managed by "The use technology of a special synthetic magnetic field"
- Section 7 : Engine oil caused by the combustion of fuel oil managed by "The use technology of a special synthetic magnetic field"
- Section 8 : Ignition timing of heat engine by fuel oil managed by "The use technology of a special synthetic magnetic field"
- Section 9 : Occurrence of a new unknown explosive vaporous expansion pressure by fuel oil managed by "The use technology of a special synthetic magnetic field"
- Section 10 : Magnitude of molecular vibration energy by fuel oil managed by "The use technology of a special synthetic magnetic field"
- Section 11 : Harmful exhaust gas by fuel oil managed by "The use technology of a special synthetic magnetic field."
- Section 12 : The decrease of carbon dioxide (CO₂) by fuel oil managed by “The use technology of a special synthetic magnetic field”
- Section 13 : The decrease of the micro-particulate matter (PM₁₀ or PM_{2.5}) by fuel oil managed by “The use technology of a special synthetic magnetic field”
- Section 14 : The decrease of nitrogen oxide (NO_x) by fuel oil managed by “The use technology of a special synthetic magnetic field”
- Section 15 : About “E-oiler” device and “Trans-master” device
- Section 16 : The references in “The use technology of a special synthetic magnetic field”

Section 1. About technical background.

- (a) About a limit of the speed that a substance cuts a "Special synthetic magnetic field",

- (b) Because the change rate of magnetic flux density by cutting of magnetic flux by a substance becomes near infinite theoretically, according to "The use technology of a special synthetic magnetic field" being based on "Electromagnetic induction theory of Faraday", the characteristic change of a substance grows so dramatically as not to be thought by the conventional technology and science.
- (c) In other words, when fuel oil, water and air are moved in an alternating magnetic field that is constituted by the plural "Special synthetic magnetic field" and "Special synthetic magnetic field" is cut, an "Electromagnetic induction formula of Faraday" is applied.
- (d) According to an "Electromagnetic induction formula of Faraday", a formula is $E = - (d\Phi/dt)$.
But, item "E" is the electronic energy by the magnetism that is induced to an atom of a substance and the item $(d\Phi/dt)$ is a rate of change of the magnetic flux.
- (e) Furthermore, "Electromagnetic induction formula of Faraday" mentioned above is applied to not only the permanent magnet but also an alternating current electromagnet constituting "Special synthetic magnetic field".
- (f) By the way, when "Special synthetic magnetic field" is cut by a substance, the time of item (dt) becomes to nearly zero by speed of a substance.
- (g) Therefore, according to "Electromagnetic induction formula of Faraday", the electronic energy by the magnetism expressed with the item "E" becomes the infinite big electronic energy that is induced to an atom of a substance only the time of near zero that is expressed with item (dt) by cutting "Special synthetic magnetic field".
- (h) In other words, because an extreme high electronic energy by the magnetism is induced to an atom of a substance by cutting "Special synthetic magnetic field", totally different physical characteristic change from the conventional physical characteristic is generated to molecules of the substance.
- (i) By the way, the effect caused by the time for cutting of "Special synthetic magnetic field" that can give the characteristic change to a substance is explained as follows.
- (i-1) Particularly, the moves of fuel oil, water and air along the alternating magnetic fields constituted by "E-oiler" device and "Trans-master" device are explained as follows.
- (i-2) According to Faraday's law, when a substance cuts a magnetic flux, the electronic energy by the magnetism caused by the change rate of the magnetic flux density $(d\Phi/dt)$ is induced to an atom of the substance.
- (i-3) Therefore, the special molecular vibration energy by the magnetism is generated in the molecule of the substance.

- (i-4) In the above case, the magnitude of the special molecular vibration energy by the magnetism of a substance increases in proportion to the increase in the change rate of the magnetic flux density ($d\Phi/dt$).
- (i-5) However, when the change rate of the magnetic flux density ($d\Phi/dt$) is further increased, a limit that no special molecular vibration energy by the magnetism can be generated to the molecule of a substance appears.
- (i-6) The rate of change of the magnetic flux density ($d\Phi/dt$) which has attained to this limit is tentatively referred to as the validity maximum change rate of magnetic flux density ($d\Phi/dt$ max).
- (i-7) Therefore, in order to generate the greatest characteristic change in the molecule of fuel oil, water and air by inducing electronic energy by the magnetism to the atoms of fuel oil, water and air, it is necessary to let the rate of change of magnetic flux density approach the validity maximum rate of change of magnetic flux density ($d\Phi/dt$) as much as possible.
- (j) According as the time that "Special synthetic magnetic field" is cut by a substance is shortened gradually, the electronic energy by the magnetism induced to a substance is increased by contraries and finally, it attains to the condition that phenomenon by electromagnetic induction cannot be generated.
- (k) Therefore, when the time of cutting of "Special synthetic magnetic field" becomes shortest (dt min), because the extreme high level electronic energy by the magnetism is generated, the greatest molecule vibration energy by the magnetism is generated to the molecules of a substance.
- (l) According to the test of cutting of "Special synthetic magnetic field", there is possibility that the time (dt min.) is changed by the difference of molecular structure.
- (m) When the time of cutting of "Special synthetic magnetic field" is shorter than the time (dt min) mentioned above, the electronic energy by the magnetism induced to the substance can be never generated, and as a result similarly molecular vibration energy of by the magnetism of the substance can be never generated, too.
- (n) Therefore, in the condition with the time (dt min.) the biggest electronic energy by the magnetism is induced to an atom of the substance, and the biggest molecular vibration energy is generated to the molecules of the substance at the same time.
- (o) In addition, in the condition with the time (dt min.) I name temporarily this movement speed of the substance "The most suitable speed for the decrease of the fuel consumption".

Section 2 : About “The use technology of a special synthetic magnetic field”

- (1) The following first conditions and the second condition are essential to cause the biggest physical characteristic change with a substance.

As the first condition, the movement speed of the substance must cut "Special synthetic magnetic field" with a condition of "The most suitable speed for the decrease of the fuel consumption" basically so that the biggest electronic energy by the magnetism is induced to the substance.

- (a) When the substance is moved in an alternating magnetic field constituted by the permanent magnets or is moved in an alternating magnetic field made by the alternating current electromagnet, the substance can cut "Special synthetic magnetic field".
 - (b) Therefore, in the conversion point of the magnetic poles, the electronic energy by the magnetism (E) induced to an atom of a substance by electromagnetism becomes nearly infinite energy level and the unimaginable physical different characteristic change occurs in the molecules of a substance dramatically.
 - (c) Furthermore, from view point of utility by a “The use technology of a special synthetic magnetic field”, it is important that the electronic energy by the magnetism induced to an atom of a substance becomes as high energy as possible and similarly it is important too that the electronic energy by the magnetism as repeatedly as possible is induced to the atom of a substance by at the same time.
- (2) As the second condition, about "E-oiler" device consisting of many permanent magnets in particular, it is important too that the speed of moving of the substance is decided so that the cycle of the molecular natural frequency of a substance that a substance originally has, can agree with the cycle of molecular vibration energy that occurs by cutting "Special synthetic magnetic field".
- (a) When the molecule of a substance cuts "Special synthetic magnetic field" by the speed of moving that can satisfy the second condition mentioned above, because the totally physically different characteristic change can occur, namely the greatest molecular vibration energy of a substance can occur, and as a result a resonance phenomenon is produced and an epoch-making effect can be generated.
 - (b) The "Special synthetic magnetic field" that are constituted by the permanent magnet and an alternating current electromagnet, is belong to the extension of the electromagnetic induction technology theoretically of "Electromagnetic induction formula of Faraday" and are the extension technologies of a generator and induction motor basically.

- (c) Therefore, when the first condition and the second condition are satisfied each by "The use technology of a special synthetic magnetic field", because the totally physically unimaginable characteristic change can be generated to molecules of fuel oil, water and the air, "The use technology of a special synthetic magnetic field" can be used as many new basic technologies in the fields of many industries.

Section 3 : About the explanation with the quantum theory by "The use technology of a special synthetic magnetic field"

- (a) By "The use technology of a special synthetic magnetic field", the effect and the phenomenon that totally physically different characteristic change occurs so dramatically as not to be able to be thought by the conventional technology and science, are explained as follows.
- (b) The electronic energy in the phenomenon that we generally experience is the electronic energy expressed with a principal quantum number in the definition of quantum theory.
- (c) For example, the electronic energy caused by the radioactivity in the definition of quantum theory, is the electronic energy expressed with a spin quantum number and a state of motion of electron caused by the radioactivity is basically different from a state of motion of electron caused by conventional phenomenon expressed with a principal quantum number.
- (d) Therefore, because the electronic energy caused by the radioactivity is basically different from the electronic energy caused by general phenomenon, the phenomenon caused by the radioactivity and a conventional general phenomenon, can not interfere mutually.
- (e) Similarly, according to fuel oil managed by "The use technology of a special synthetic magnetic field", because the electronic energy by the magnetism induced to an atom of a substance is the electronic energy expressed with a magnetic quantum number in the definition of quantum theory, therefore, a state of motion of electron is basically different from a state of motion of electron caused by general phenomenon.
- (f) Therefore, according to fuel oil managed by "The use technology of a special synthetic magnetic field", occurrence of a new unknown explosive vaporous expansion pressure by the magnetism without generating heat, can not be disturbed by high temperature and high pressure of a cylinder of heat engine.
- (g) Therefore, according to fuel oil managed by "The use technology of a special synthetic magnetic field" in a conventional engine technology it is an inevitable result that the phenomenon of the unthinkable decrease of the fuel consumption and a phenomenon of the unthinkable decrease of exhaust gas occur.

The test results caused by the result of the research mentioned above exist, [“Test data in Chapter 1”](#), [“Test data in Chapter 2”](#) and [“Test data in Chapter 3”](#), and they are explained as follows.

Section 4 : A reduction rate of the fuel consumption of heat engine by fuel oil managed by "The use technology of a special synthetic magnetic field"

The effects of heat engine by the effect of fuel oil managed by "The use technology of a special synthetic magnetic field" by basing on the results of the running tests mentioned above are explained as follows.

- (a) According to the test results that were provided on the running tests of heat engine in ["Test data in Chapter 1"](#), ["Test data in Chapter 2"](#) and ["Test data in Chapter 3"](#), the many phenomena that not only a explosive thermal expansion pressure by conventional combustion but also a new unknown explosive vaporous expansion pressure by the magnetism without generating heat, were generated in the inside of the cylinders of many kinds of heat engines without exception, were surely proved.
- (b) Therefore, the test results and phenomenon to prove that a new unknown explosive vaporous expansion pressure by the magnetism without generating heat were generated by the many driving for tests of heat engines, are listed up as follows.

They exist in "Item A", "Item B", "Item C", "Item D" and "Item E" each as follows.

“Item A” : About a decrease rate of the fuel consumption in heat engine, refer to Section 1, Section 3, Section 5, Section 7, Section 9 and Section 11 in [“Test data in Chapter1”](#) below,

- (a) Section 1 : About data of a strict driving for test with "Eco-oiler" device by "A foundation : Japanese Automobile Travel Engineering Society",
- (b) Section 3 : About data of the running tests with "E-oiler" device by "Tokushima industry junior college",
- (c) Section 5 : About data of the severe running tests of a diesel engine car on road with "E-oiler" device by "Company of Waseda environmental laboratory",
- (d) Section 7: Data of the running tests of LP gas cars on road by "Minato transportation taxi Co. Ltd.," (Naha-City, Okinawa),
- (e) Section 9 : About data of the running tests on road of the large truck,
- (f) Section 11 : About data of the voyage tests of a main engine of "The third Snmiwakamaru" (2,700HP) with "Trans-master" device,

- (g) By the way, many running tests by various kinds of heat engine more than 2000 were already performed by the fuel oil managed by "The use technology of a special synthetic magnetic field".

As for the test results mentioned above, they were the test results and the approximately equal test results that each had been already recorded in "[Test data in Chapter 1](#)" and "[Test data in Chapter 2](#)".

- (h) As mentioned above, though naturally, according to the strict running tests of heat engine, though a decrease rate of the fuel consumption entirely must be zero, a big decrease rate of the fuel consumption of 10%~20% was already generated without exception regardless to the kind of heat engine and to the kind of fuel oil.

Section5 : Temperature drop caused by the combustion of fuel oil managed by "The use technology of a special synthetic magnetic field"

“**Item B**” : About a temperature drop of exhaust gas of a diesel engine,

- (a) Section 4 in "[Test data in Chapter 1](#)",
Section 4 in "[Test data in Chapter 2](#)" : Explanation of data of the first voyage test, (b) The big decrease numerical value of 14 °C in temperature of exhaust gas was accomplished by the voyage test of "The third Sumiwaka-maru" of the test ship with a "Trans-master" device A.

Section 6 : Noise and vibration caused by the combustion of fuel oil managed by "The use technology of a special synthetic magnetic field"

“**Item C**” : About the drops of a noise and vibration of diesel engine,

- (a) Data sheet No. 3 and No. 7 in Section 9 in "[Test data in Chapter 1](#)"
About data of the running tests on road of the large truck,
(a-1) The opinions of the driver that were recorded to data sheet for test in particular :
The engine noise and vibration were greatly decreased.
(b) About the drops of vibration and noise by the ship engine of the test ship
(b-1) Because a pointer of an indicator became the almost stop condition in diesel engine of a test ship by using heavy oil "A" managed by "The use technology of a special synthetic magnetic field", it was possible to read 1 / 10th of the minimum scale of an indicator.

- (b-2) In other words, by occurrence of a new unknown explosive vaporous expansion pressure by the magnetism without generating heat prior to a explosive thermal expansion pressure, the pressure for pushing down a piston is made average and the maximum clash value to the piston is decreased greatly, and as a result vibration and a noise in heat engine decreased dramatically.

Section 7 : Engine oil caused by the combustion of fuel oil managed by "The use technology of a special synthetic magnetic field"

“**Item D**” : About a dramatic increase of a life span of engine oil

- (a) Because combustion temperature in the inside of a cylinder of heat engine decreased without exception and the maximum clash value to the piston was decreased greatly, a blot and deterioration of engine oil were decreased greatly and the life span of engine oil was prolonged dramatically.

Section 8 : Ignition timing of heat engine by fuel oil managed by "The use technology of a special synthetic magnetic field"

“**Item E**” : When fuel oil managed by "The use technology of a special synthetic magnetic field" was used, it often occurred in the running tests of heat engine that a peculiar noise was generated to heat engine when an ignition timing and the jet timing of heat engine were too early.

- (a) In other words, because the timing that a piston is pushed down, becomes earlier than conventional timing of existing heat engine by occurrence of a new unknown explosive vaporous expansion pressure by the magnetism without generating heat prior to explosive thermal expansion pressure by conventional combustion, namely a start of timing that the pressure by strong pushing down is added to a piston, becomes earlier virtually and as a result on the contrary braking action to heat engine occurs.
- (b) Therefore, the above phenomenon occurs when ignition timing of existing heat engine is already set too early in particular.
- (c) Therefore, because the accumulation of rotation inertia energy of a crankshaft by the explosion pressure of heat engine by the above braking action of heat engine is greatly consumed, abnormal noise caused by big energy loss of heat engine are generated to existing heat engine, as a result a increase of the fuel consumption are greatly generated at the same time.
- (d) Based on the above test results it was proved that the practical big explosive vaporous expansion pressure by the magnetism without generating heat prior to explosive thermal expansion pressure by conventional combustion, occurs.

Section 9 : Occurrence of a new unknown explosive vaporization expansion pressure by fuel oil managed by "a use technology of a special synthetic magnetic field"

“**Item F**” : About conclusions

- (1) The test results and phenomena by fuel oil managed by “The use technology of a special synthetic magnetic field” of “**Item A**”, “**Item B**”, “**Item C**”, “**Item D**” and “**Item E**”.

It was perfectly proved that a new unknown explosive vaporous expansion pressure by the magnetism without generating heat prior to the conventional explosive thermal expansion pressure occurred.

- (2) When the fuel oil managed by "The use technology of a special synthetic magnetic field" that have ultra decreasing condition of viscosity is injected inside into a sealed cylinder with high temperature and high pressure, a severe bumping phenomenon is caused at the same time the fuel oil becomes to super micro-particulate matter.
- (3)As a result, above big electronic energy by the magnetism induced to an atom of fuel oil managed by "The use technology of a special synthetic magnetic field" is suddenly released in a cylinder of heat engine as the trigger of the bumping phenomenon, and as a result it is thought that a new unknown explosive vaporous expansion pressure by the magnetism without generating heat occurs.

Section 10 : Magnitude of molecular vibration energy by fuel oil managed by "The use technology of a special synthetic magnetic field"

- (a) About the presumption of molecular vibration energy by the magnetism accumulated to fuel oil managed by “The use technology of a special synthetic magnetic field” caused by the decrease of viscosity without the temperature rise
- (b) The state of a decrease in viscosity of fuel oil managed by “The use technology of a special synthetic magnetic field” is the completely state of an abnormal decrease in viscosity as dramatically as not to be able to be thought by the decrease in viscosity caused by normal heating.
- (b-1) Therefore, it is presumed that the molecular vibration energy that is given to the molecule of fuel oil managed by “The use technology of a special synthetic magnetic field” is equivalent to unimaginably big heat energy.
- (c) About the use conditions of light oil or heavy oil "A" managed by “The use technology of a special synthetic magnetic field”

- (c-1) When a ball valve based on the Japanese Industrial Standards (JIS) in a hose of light oil managed by "The use technology of a special synthetic magnetic field" to the engine of a car is installed, because the penetration ability of light oil becomes unimaginably strong by the intense decrease viscosity, the phenomenon that ability for completely closing of the ball valve can't work occurs.

It is a surprising thing that the ability for closing of a ball valve that is based on Japanese Industrial Standard (JIS), can't work.

- (c-2) Similarly, as for the heavy oil "A" which was stored in the spare tank (1, 000 liters) of "The third Sumiwaka-maru" of the test ship, when heavy oil "A" was sent to "Trans-master" device repeatedly by a gear pump based on the Japanese Industrial Standards (JIS), the phenomenon that heavy oil "A" was leaked outside from the output axis of the gear pump, was generated .

Section 11 : Harmful exhaust gas by fuel oil managed by "The use technology of a special synthetic magnetic field."

- (a) From the heat engine, the exhaust gases are cooled by the atmosphere after the combustion gases that have not yet been perfectly burnt out are discharged from exhaust pipe to the atmosphere, and as a result the harmful gases such as carbon dioxide (CO₂) and hydrocarbon (HC) and carbon monoxide (CO) and nitrogen oxide (NO_x) and micro-particulate matter (PM₁₀ or PM_{2.5}) are discharged to the atmosphere.
- (b) However, according to fuel oil managed by "The use technology of a special synthetic magnetic field", because explosive vaporous expansion pressure by the magnetism without generating heat basically occurs, all harmful exhaust gases are almost burnt out in combustion in the inside of a cylinder of heat engine.

Section 12 : The decrease of carbon dioxide (CO₂) by fuel oil managed by "The use technology of a special synthetic magnetic field"

- (a) The conventional disposal technology of exhaust gas with systems such as a filter and a catalyst or urea SCR of heat engine, have only ability to prevent environmental pollution by decreasing an exhaust of harmful exhaust gas to the atmosphere.
- (b) In other words, the systems such as a filter, a catalyst and the urea SCR, do not completely have ability of decreasing exhaust gas by making the high combustion efficiency in heat engine and quantity of the fuel consumption can't be decreased at all.

Therefore, the quantity of carbon dioxide (CO₂) is not decreased at all.

- (c) When fuel oil managed by "The use technology of a special synthetic magnetic field" is used by many running tests of various heat engines, using "E-oiler" device and "Trans-master" device which were already developed until now, the rate of decline of 10%~ 20% of the fuel consumption can be surely actualized.
- (d) Therefore, not only a big decrease of carbon dioxide (CO₂) but also the economical big effect can be surely actualized.

Section 13 : The decrease of the micro-particulate matter (PM₁₀ or PM_{2.5}) by fuel oil managed by "The use technology of a special synthetic magnetic field"

- (a) Because the new unknown ultra strong explosive vaporous expansion pressure by the magnetism without generating heat occurs in combustion in the inside of a cylinder of heat engine, the fuel oil is subdivided necessarily to a super micro-particulate matter.
- (b) Therefore, according to light oil managed by "The use technology of a special synthetic magnetic field" not only the conventional black smoke (PM₁₀) but also the conventional micro-particulate matter (PM_{2.5}) in the exhaust gas are decreased greatly together.

Section 14 : The decrease of nitrogen oxide (NO_x) by fuel oil managed by "The use technology of a special synthetic magnetic field"

- (a) In addition, according to fuel oil managed by "The use technology of a special synthetic magnetic field" because a new unknown unimaginably big explosive vaporous expansion pressure by the magnetism without generating heat is generated, temperature in combustion in a cylinder of heat engine decreases greatly and therefore, nitrogen oxide (NO_x) can be decreased greatly.

Section 15 : About "E-oiler" device and "Trans-master" device

- (a) "E oiler" device with a permanent magnet and "Trans-master" device with an alternating current electromagnet are the product name each made by plural "Special synthetic magnetic fields".
- (b) It is a most important to drive with same speed before and after the installations of "E oiler" device and "Trans-master" device to get the reduction effects of the biggest fuel consumption.

Only when an automobile is driven in the running condition mentioned above, the rate of decline of the fuel consumption of 10% - 20% can be provided.

Section 16 : The references in "The use technology of a special synthesis magnetic field"

1. Reference 1 : About "[Test data in Chapter 1](#)"
 - (a) About "The most suitable speed for the decrease of the fuel consumption" in heat engine
 - (a-1) About the running tests of the car with "E-oiler" device, the flow speeds of gasoline and the light oil are 5cm/sec. ~ 10cm/sec.
 - (a-2) About the voyage test of the ship engine with "Trans-master" device, the flow speeds of heavy oil "A" are 4m/sec.~ 5m/sec.
2. Reference 2 : About "[Test data in Chapter 2](#)"
 - (a) The contents of a study of "[Test data in Chapter 2](#)" is basically same to the contents of a study of "[Test data in Chapter 1](#)".
 - (b) Contents of the test
 - (b-1) It is a voyage test about main diesel engine with heavy oil "A" of the ship.
 - (b-2) The reduction rate of the fuel consumption is provided.
 - (b-3) Measuring temperature of the exhaust pipe of the main engine.
 - (b-4) About a boiler : Refer to Section 11 in "[Test data in Chapter 2](#)"
 - (c) Problems in the voyage test
 - (c-1) Because the influence that the conditions of a sea such as the tide and wind and the wave give to the fuel consumption of the main engine of the ship is very big, it is very difficult to decide practical fuel consumption.
 - (c-2) However, because an auxiliary engine is an engine to get a power supply for living of the members of crewing, the auxiliary engine is not affected at all by the conditions of the sea such as the tide and wind or the wave in spite of using heavy oil "A" same as the main engine.
 - (c-3) Therefore, as for the reduction rate data of the fuel consumption of the auxiliary engine, the data of the reduction rate of the fuel consumption of the auxiliary engine can be represented as data of the main engine.

3. Reference 3 : About "[Test data in Chapter 3](#)"

The contents of the study of "[Test data in Chapter 3](#)" are the basically same to "Introduction" ~ Section 3 of "[Test data in Chapter 1](#)"

(a) Contents of the test

- (a-1) Dramatic drop phenomenon of ORP (Oxidation-reduction Potential)
numerical value of water : The measurements fall to 280mv from 640mv.
- (a-2) The sterilization function of water or air managed by "The use technology of a special synthetic magnetic field", is different from the sterilization function caused by the general ultraviolet rays and ozone and radiation fundamentally.

(b) Problems in the test

- (b-1) About the use method of the characteristic change of water and the air
- (b-2) About usage of the air in particular by "Electromagnetic air cleaner"
- (b-3) About the relation of quantity of air in particular and the room of living residence

End

March 1, 2017

929-1171

Address : Ni-160-2, Kizu, Kahoku-City, Ishikaw-Pref., Japan

Name : Tatsuo Komedashi

Mail: wxdxn7493000@ybb.ne.jp

Home Page: URL : <http://www.vzporization-energy.com/>